

DATASHEET

Built-in fan set for wall housings, com. incl. thermostat and connection cables

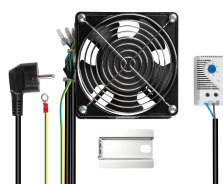

General data

Fan complete set for all 19" wall housings 1- and 2-part, flat pack, Basic
 Incl power cable 1.5 m, thermostat, mounting bracket and grounding cable 1m
 Dimensions fan 120 x 120 x 38 mm, air capacity 160 m³/h
 Delivery incl. mounting material

Technical properties

| | |
|------------------------------|----------------|
| Air circulator | True |
| Built as slide-in ventilator | False |
| EMC-version | False |
| Mounting method | Screw mounting |

This datasheet was created automatically on 09-04-2026 . Technical changes reserved.



DATASHEET

Built-in fan set for wall housings, com. incl. thermostat and connection cables

| | |
|------------------------------------|-------------|
| Operating voltage at AC 50 Hz | 230 - 230 V |
| Operating voltage at AC 60 Hz | 3 |
| Operating voltage at DC | 3 |
| Roof ventilator | True |
| Suitable for 19 inch rack mounting | False |
| Suitable for wall built-in | True |
| Voltage type | AC |
| With filter | False |

Available variants

| ArtNr. | Bezeichnung | Color | Number of fans | Width | Height | Depth | Rated power | Volume flow, freeblowing |
|----------|---|-------|----------------|--------|--------|-------|-------------|--------------------------|
| 691664.1 | Built-in fan set for wall housings, com. incl. thermostat and connection cables | black | 1 | 119 mm | 119 mm | 38 mm | 22 W | 160 m ³ /h |

Drawings

This datasheet was created automatically on 09-04-2026 . Technical changes reserved.



DATASHEET

Built-in fan set for wall housings, com. incl. thermostat and connection cables

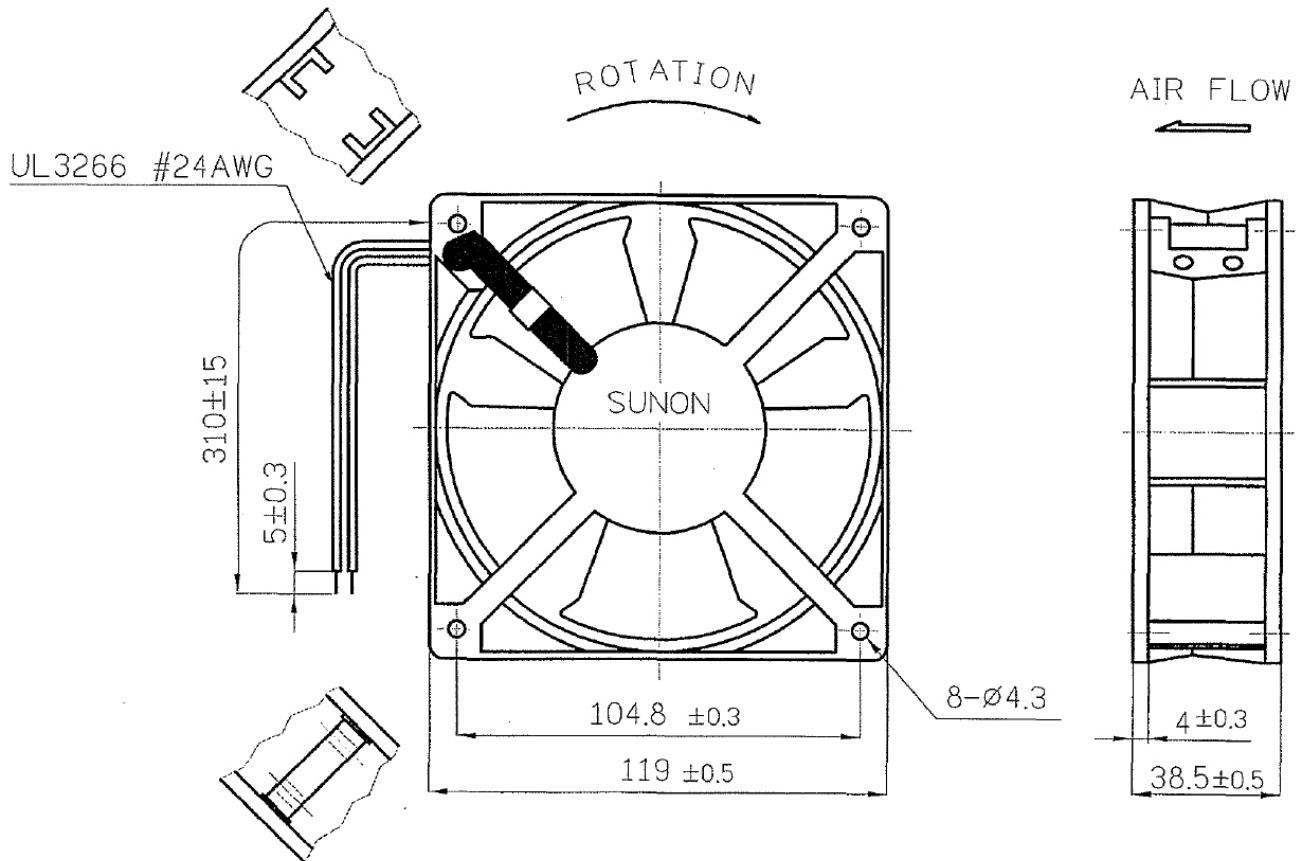

This datasheet was created automatically on 09-04-2026 . Technical changes reserved.

